

P/N CC-48

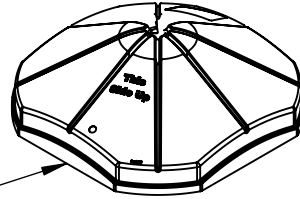

P/N CC-127

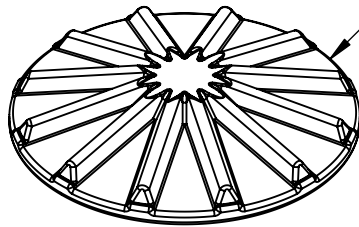

P/N CC-L36

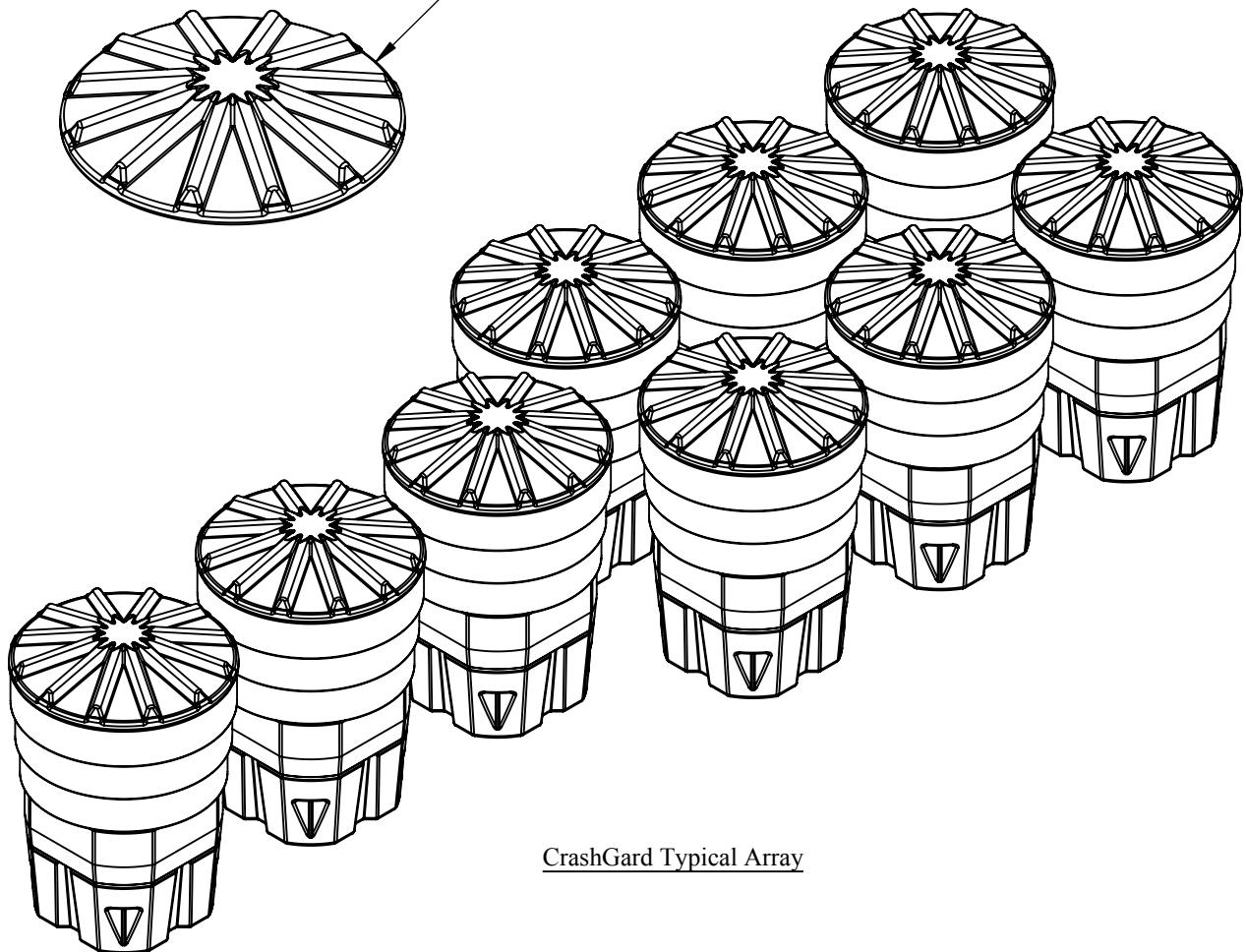

CrashGard Typical Array

## CrashGard Sand Barrel

Plastic Safety Systems, Inc.

Designator  
to be assigned

SHEET NO.

DATE:

1 of 6

1/19/07

### Intended Use

The Plastic Safety Systems, Inc. (PSS) CrashGard™ Sand Barrel System is a non-redirective, gating sand barrel, or crash cushion. Sand barrels are designed to protect fixed objects, whether permanent or temporary. Sand barrels are designed to reduce the likelihood of a vehicle impacting the object.

The CrashGard Sand Barrel System meets NCHRP-350, Test Level 3 requirements.

Properly designed arrays will decelerate the vehicle within the parameters described in NCHRP-350.

CrashGard Sand Barrels shall be filled with Washed Concrete Sand, ASTM C-33 or equivalent.

### System Design and Configuration

The CrashGard Sand Barrel System consists of three (3) components:

- **Barrel, P/N CC-48:**
  - Overall dimensions: 36" [914mm] diameter, 48" [1219mm] height.
  - Features:
    - Designed so that one barrel satisfies all weight requirements: 200, 400, 700, 1,400 and 2,100 lbs.
    - Barrels nest easily when empty.
    - Easily transported by forklift or with CrashGard Hoist Lift Ring.
    - Accommodates reflective sheeting.
  
- **Insert, P/N CC-I27:**
  - Overall dimensions: 27" [686mm] square, 10.4" [264mm] height.
  - Features:
    - The insert, when installed, allows for ballast of either 200, 400, or 700 lbs. of sand.
    - The insert is not required to fill barrels to 1,400 or 2,100 lb. levels.
    - Inserts will nest.
  
- **Lid, P/N CC-L36:**
  - Overall dimensions: 36.5" [927mm] diameter, 6.6" [168mm] height.
  - Features:
    - The lip of the lid snaps into a groove in the top of the barrel and provides a tamper-proof fit.
    - May prevent water infiltration and vandalism.
    - Lids will nest.

#### **Contact Information:**

**Plastic Safety Systems, Inc.**  
2444 Baldwin Rd.  
Cleveland, OH 44104  
800-662-6338 / [www.plasticsafety.com](http://www.plasticsafety.com)

## CrashGard Sand Barrel

**Plastic Safety Systems, Inc.**

Designator  
to be assigned

—SHEET NO.

2 of 6

—DATE:

1/19/07



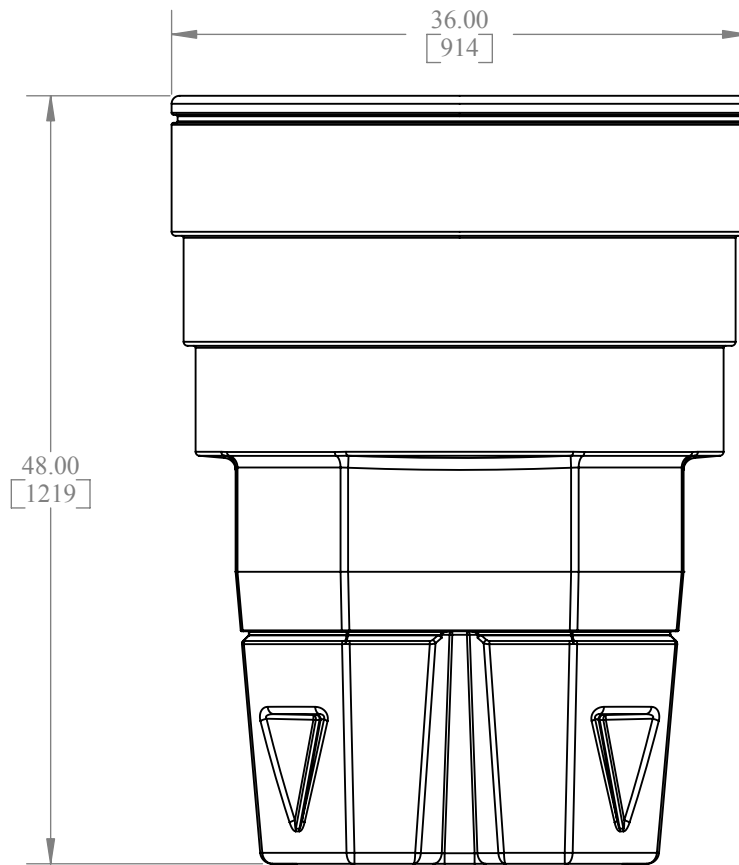
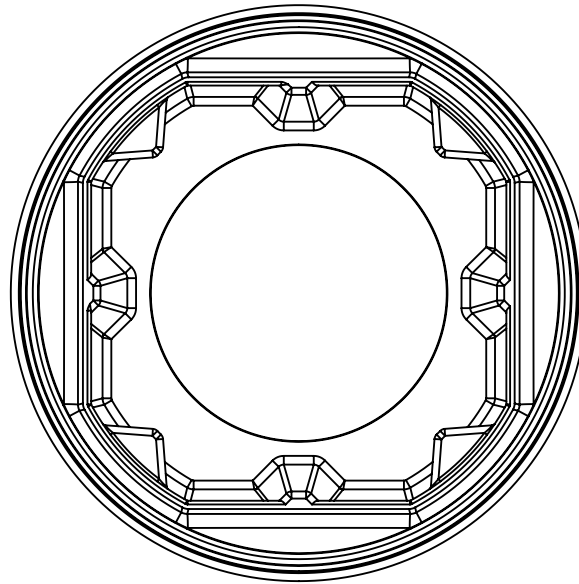

Sand Barrel P/N CC-48

## CrashGard Sand Barrel

Plastic Safety Systems, Inc.

Designator  
to be assigned

SHEET NO.

DATE:

4 of 6

1/19/07

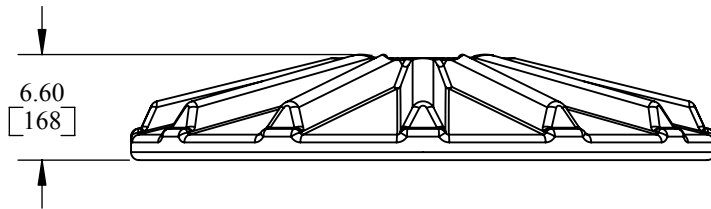
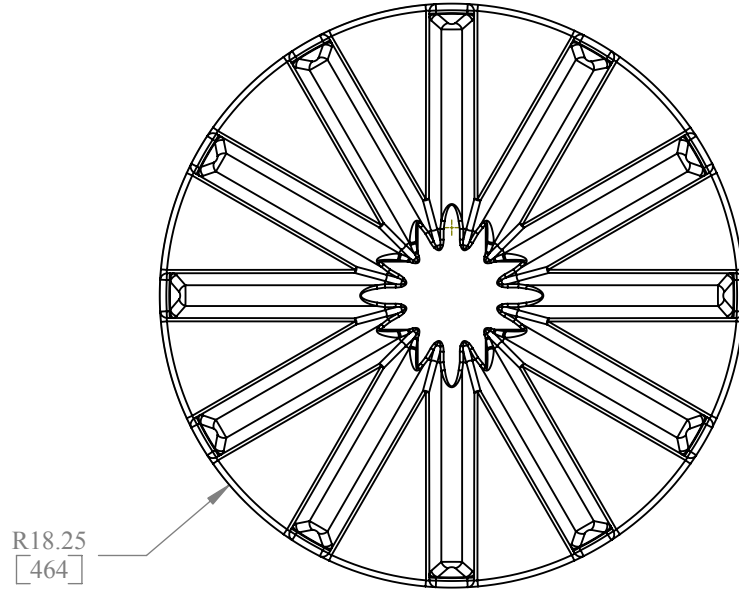

Lid P/N CC-L36

# CrashGard Sand Barrel

Plastic Safety Systems, Inc.

Designator  
to be assigned

SHEET NO.	DATE:
5 of 6	1/19/07

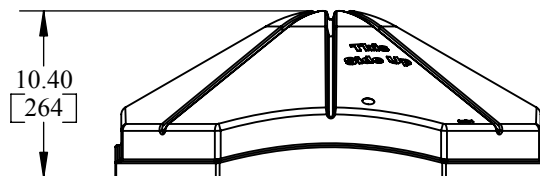
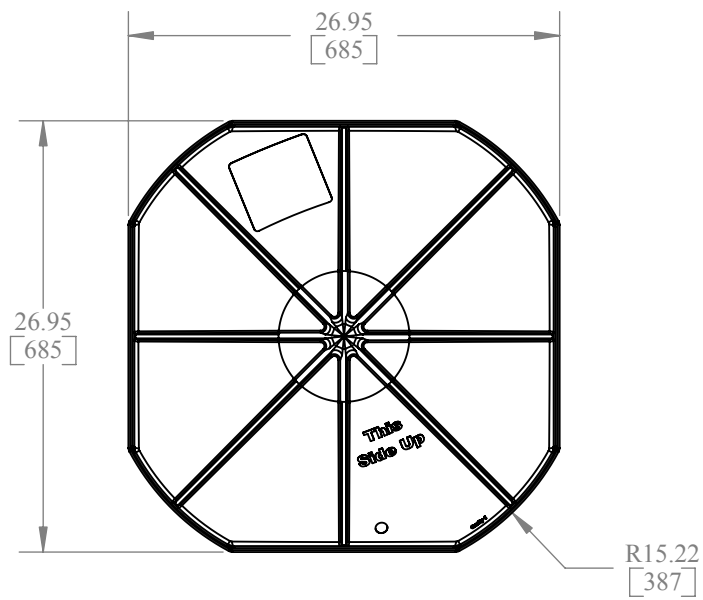

Insert P/N CC-127

## CrashGard Sand Barrel

Plastic Safety Systems, Inc.

Designator  
to be assigned

SHEET NO.

DATE:

6 of 6

1/19/07